



Open-Frame SAW Touch LCD Monitor (DUST-PROOF)



Main Features:

- IP6X dust-proof standard, effectively protecting the reflectors and the transducers.
- 15.0", 17.0" and 19.0" sizes available.
- Proven SAW touch technology.
- The perfect solution for integrating touch and LCD.
- Dual USB and RS232 touch interface.
- High brightness, high contrast, fast response time.
- Horizontal and vertical mounting options via brackets plus VESA mounting.
- Worldwide agency approvals held, ETL, FCC, CE, CB plus RoHS compliancy.

Accessories

- AC Adaptor
- Power Cable
- USB Cable
- RS232 Cable
- VGA Cable
- Driver CD
- Brackets & Screws

Technical specification:

| | 15 " | 17 " | 19 " |
|--|---|----------------------------------|---------------------------------|
| Model | KOT-0150US-SA4BP | KOT-0170US-SA4BP | KOT-0190US-SA4BP |
| Structure | Metal-cased open frame ,with front dust-proof plastic bezel | | |
| LCD Type | 15 " Active matrix TFT-LCD | 17 " Active matrix TFT-LCD | 19 " Active matrix TFT-LCD |
| Active Area | 12 " (304mm)×9 " (228mm) | 13.3 " (338mm)×10.6 " (270mm) | 14.8 " (376.3mm)×11.9 " (301mm) |
| Monitor Dimensions | Width: 360mm | Width: 392mm | Width: 434mm |
| | Width with brackets: 400mm | Width with brackets: 432mm | Width with brackets: 474mm |
| | Height: 288mm | Height: 330mm | Height: 360.5mm |
| | Height with brackets: 328mm | Height with brackets: 370mm | Height with brackets: 400.5mm |
| | Depth: 47.5mm | Depth: 50mm | Depth: 54mm |
| Suggested Resolution | 1024×768 | 1280×1024 | |
| Suggested Resolution | 1024×768 at 60,70,75 Hz; | 1280×1024 at 60,75 Hz; | |
| | 800×600 at 60,72,75 Hz; | 1024×768 at 60,70,75 Hz; | |
| | 640×480 at 60,72,75 Hz; | 800×600 at 60,72,75 Hz; | |
| | 640×400 at 70 Hz | 640×480 at 60,72,75 Hz; | |
| | 720×400 at 70 Hz | 640×400 at 70 Hz | 720×400 at 70 Hz |
| Support Colors | 16.2M | | |
| Brightness(Typ.) | Pure LCD Panel: 250cd/m2 | Pure LCD Panel: 300cd/m2 | |
| | With SAW Glass Sensor: 225cd/m2 | With SAW Glass Sensor: 275cd/m2 | |
| Response Time(Typ.) | 16ms | | |
| Viewing Angle (Typ.at Cr>10) | Horizontal(left/right): 60° /60° | Horizontal(left/right): 75° /75° | |
| | Vertical(up/down): 40° /60° | Vertical(up/down): 75° /60° | |
| Contrast Ratio(Typ.) | 450:1 | | |
| Video Input | Analog RGB | | |
| Signal Input | H/V Separate Sync. (TTL) | | |
| Video Signal Input Connector | Mini D-Sub 15-pin VGA | | |
| Frequency (H/V) | 30~80KHz / 60~75Hz | | |
| Power Supply | Type: External brick Input (line) voltage: 100-240 VAC, 50-60 Hz Output voltage/current: 12 volts at 4 amps max | | |
| Environment | Operating Temp:0~50° C Storage Temp:-20~60° C Operating RH:20%~80% Storage RH:10%~90% | | |
| MTBF | 50,000 Hours | | |
| LCD Back light Life(Typ.) | 50,000 Hours | | |
| Weight(N.W/G.W) | 3Kg / 4.5Kg | 5Kg / 7.2Kg | 5.8Kg / 8Kg |
| Power Consumption | 30W Max. | 40W Max. | 50W Max. |
| Mount Interface | 1)VESA 75mm and 100mm | | |
| | 2)Mount bracket, horizontal or vertical (Standard mount brackets are supplied) | | |
| OSD Control | Buttons: AUTO,+,POWER,-,MENU | | |
| | Function : Brightness, Contrast Ratio, Auto-adjust, Phase, Clock, H/V Location, Languages, Function, Reset | | |
| Touch screen Type | SAW 4MM thickness of touch sensor (Available Options: Thickness/Anti-glare/Tempered) | | |
| Touch System Interface | Having USB and serial interface | | |
| Touch Response time | ≤10ms | | |
| Agency Approval | ETL, FCC, CE, RoHS | | |
| Regular Warranty | 5 years for SAW Sensor; 3 years for controller; 1 year for LCD | | |

NOTE: The display SPEC. will change follow the relevant LCD panel brand and model

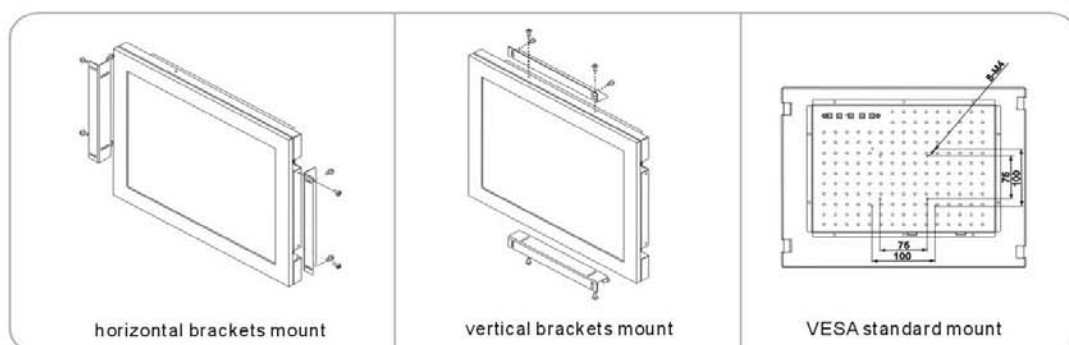

Craft Data Limited

92 Broad Street, Chesham, Bucks, HP5 3ED, UK

☎ 44 (0)1494 778235, 📠 44 (0)1494 773645

✉ sales@craftdata.co.uk , 🌐 www.craftdata.co.uk